



City of Hampton

ACCESSIBLE RESTROOM REQUIREMENTS

This handout outlines the minimum requirements for accessible restrooms found in the International Building Code 2009 (IBC) Chapter 11 and ICC/ANSI A117.1-2003.

The attached details illustrate common configurations for constructing a complying restroom. The code provides for additional options and it is the responsibility of the applicant to ensure that all of the requirements are met.

See attached diagrams for illustrations of the following requirements:

1. Clear floor space around water closet must be 60" minimum, measured perpendicular from the sidewall and 56" minimum, measured perpendicular from the rear wall. (ICC/ANSI A117.1-2003 Section 603.3)
2. Clear floor space in front of fixtures must be 30" x 48" minimum and may overlap with other required clear floor spaces and clearances. (ICC/ANSI A117.1-203 Section 305)
3. Maneuvering clearances at doorways must be maintained. (ICC/ANSI A117.1-2003 Section 404.2.3)
4. Door swing may not encroach into 60" circle of clear space of clearance for any fixture except where the room is for individual use and a clear floor space of 30" x 48" is provided beyond the arc of the door swing.
5. Grab bars are required in all accessible toilet and bathing rooms (ICC/ANSI A117.1-2003 Section 604.5):
 - Rear wall: 36" minimum in length, mounted at least 12" from the centerline of the water closet on the side closest to the wall, and 24" minimum on the transfer side.
 - Fixed side wall: 42" minimum length, extending to 12" maximum from rear wall and 54" minimum from the rear wall.
 - Vertical side wall: 18" minimum in length with the centerline of the bar located 39" to 41" from the rear wall and the bottom of the bar located 39" to 41" above the floor.
6. As a general rule, 7'-0" x 7'-0" is the minimum room size to meet all the requirements for an accessible individual user restroom.

Community Development Department - Development Services Center
22 Lincoln Street, 3rd Floor, Hampton, Virginia 23669-3522
Telephone (757) 728-2444 Fax (757) 728-2445

"Oldest Continuous English-Speaking Settlement in America - 1610"



City of Hampton

ACCESSIBLE RESTROOM REQUIREMENTS

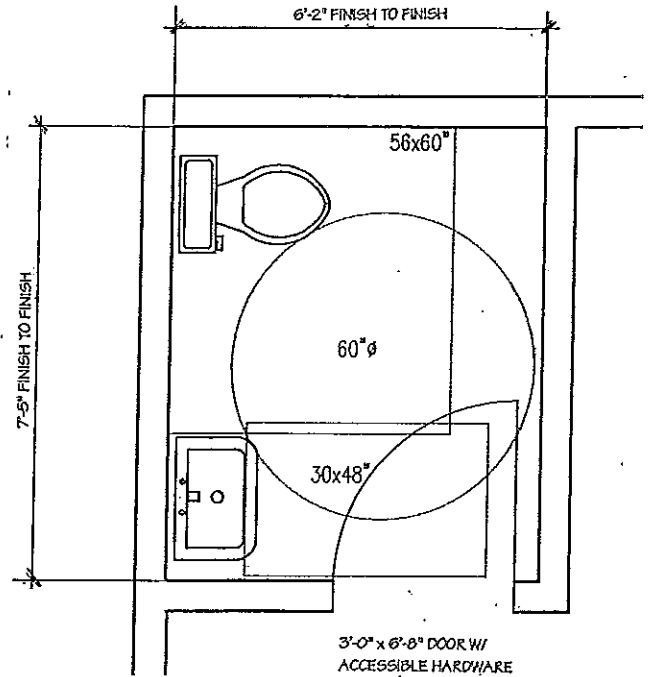
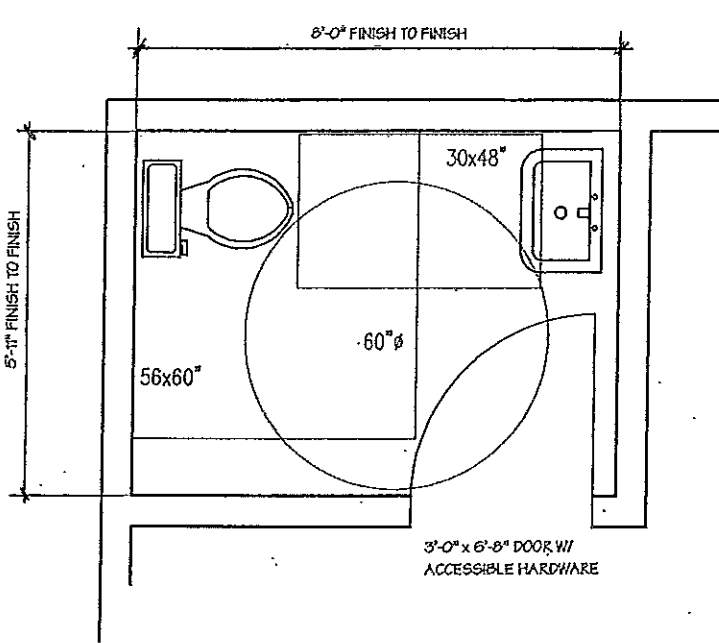

FLOOR PLAN LAYOUTS

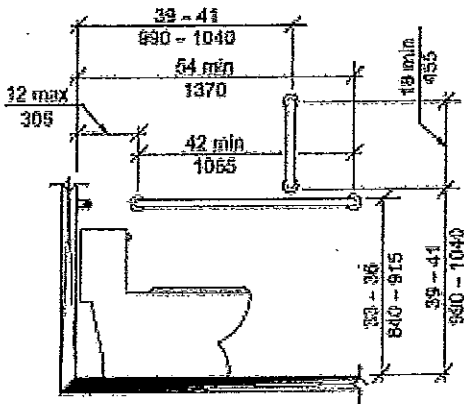

Fig. 604.5.1
Side Wall Grab Bar for Water Closet

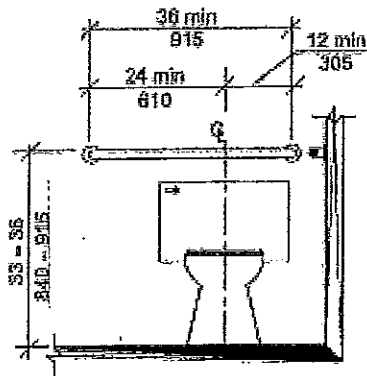

Fig. 604.5.2
Rear Wall Grab Bar for Water Closet

GRAB BAR LOCATIONS